



GREENPUMPS

MAG - DRIVE SEAL- LESS PUMPS

C A S T E R 

GPCA SERIES

ALLOY CENTRIFUGAL PUMPS

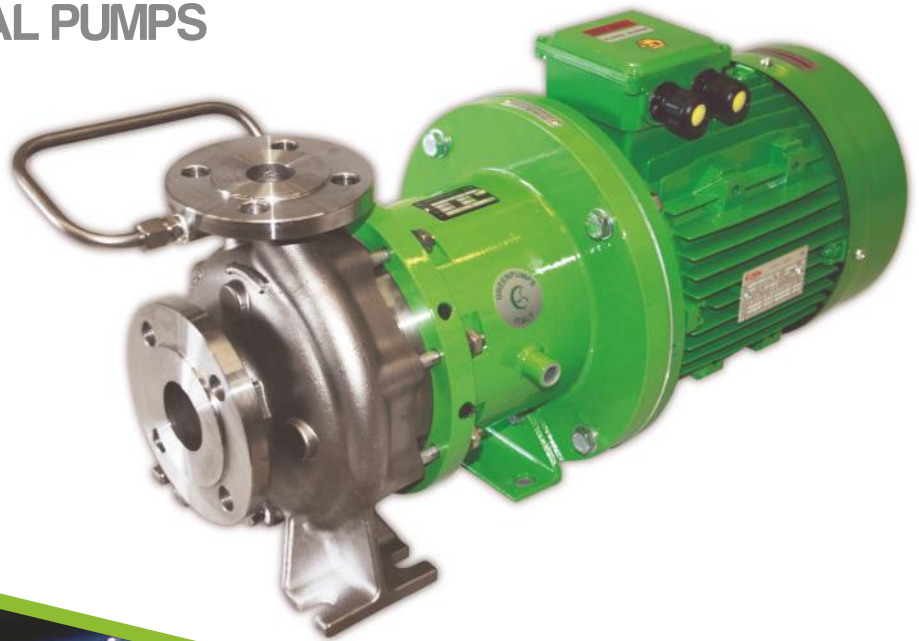

ZERO LEAKAGES FOR ENVIRONMENTAL SOLUTIONS

DESIGN FEATURES

Foot mounting, single volute casing with flanged end suction and top discharge. The impeller is hydraulically and dynamically balanced and designed to achieve high efficiency and low N.P.S.H. values. Bearing frame shaft supported by oil lubricated ball bearings, close coupled configuration available. Performances and dimensions of the GPCA pump line are in accordance with ISO 2858 — ISO 5199 — DIN 24256 — NFE 44121.

- SAMARIUM-COBALT MAGNETS STANDARD (SYNCHRONOUS MAGNET COUPLINGS ONLY NO SLIPPING)
- SILICON CARBIDE BEARINGS STANDARD

MATERIALS

- SS AISI 316
- ALLOY 20
- INCOLOY 825
- HASTELLOY B-C
- MONEL
- TITANIUM

ADVANTAGES

All pumps of the GPCA line have been designed to a modular concept so as to reduce the stock of spares with the advantage of low stocking costs. The GPCA line is back-pull-out design, therefore when the pump unit is equipped with a spacer type coupling, the complete rotor can be removed from pump casing without disturbing piping and motor.

PERFORMANCE

- FLOW: up to 2000 USGPM (450mc/h)
- HEAD: up to 500 feet (150mt)
- TEMP.: -150°F+660°F (750°F with external cooling)
- SYSTEM PRESSURES: 350 PSI (with option up to 1500 PSI)

APPLICATIONS

Particularly suited to pump liquids in any industrial field: chemical, pharmaceutical, refineries, paper mills, textile industry, food processing, sugar plants, and hazardous chemicals.

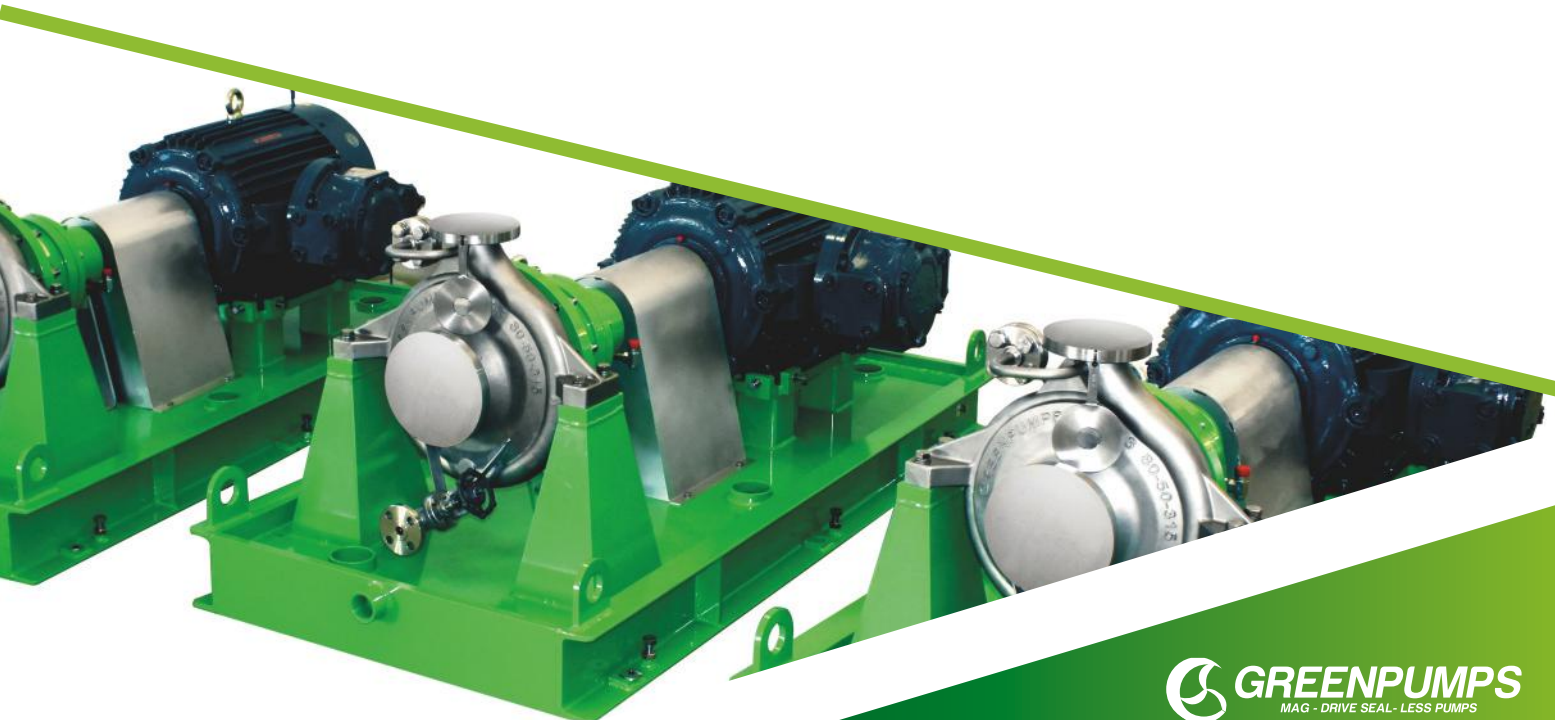

SPECIAL DUTY

JACKETED PUMPS

SEALLES MAGNETIC DRIVE

When pumping liquids which tend to solidify at low temperatures or heat sensitive liquids, the pump casing, the bracket and the bearing support can be equipped with a heating jacket.

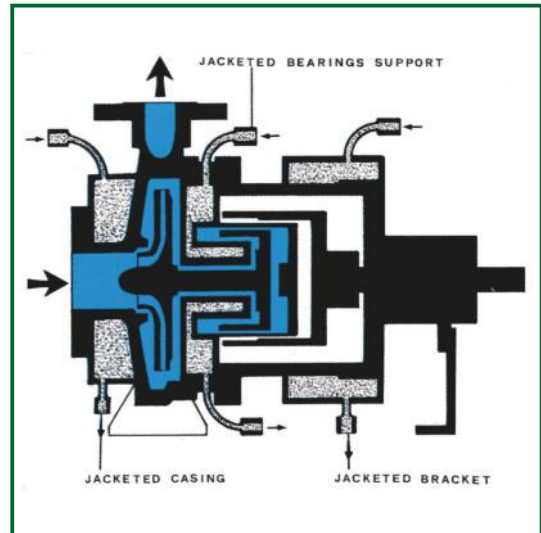

EXTERNAL HEAT EXCHANGER

SEALLES MAGNETIC DRIVE

For liquid temperatures over 300°C (600°F) rear parts of the pump, bushings, and thrust bearings, must be cooled through an external heat exchanger connected to a circulation pipe.

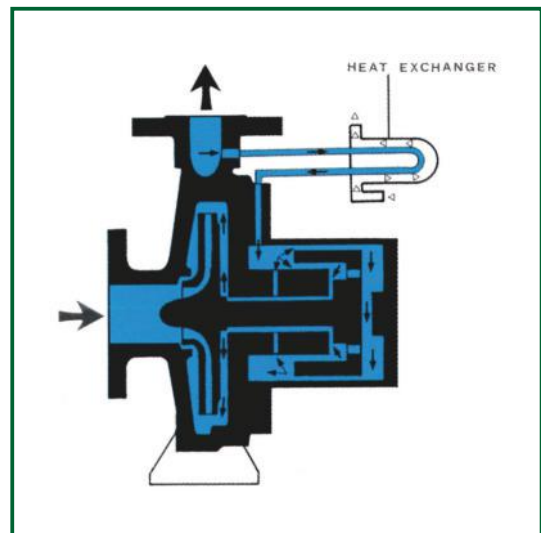

LOW NPSH PUMPS

SEALLES MAGNETIC DRIVE

For applications where the value of N.P.S.H. available on the plant is very low, the pump can be equipped with an inducer in order to reduce the required N.P.S.H.

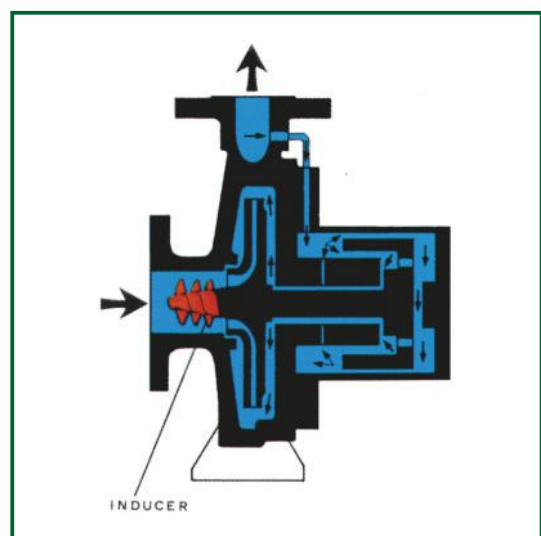

It is important to note inducers are designed for specific duty points to provide uniform eye velocity. Further, if operated outside +10% -20% of the rated capacity, an inducer will generally have an adverse effect on N.P.S.H. performance.

DIN or ANSI flanges

Lubrication system maintains highest pressure differential and allows for dead-heading

Back-pull-out hydraulic end

Replaceable casing wear ring



Shaft & bearings are supported by pump frame for withstanding hydraulic loads

Silicon carbide vs. silicon carbide sleeve and thrust bearings, with grooves to pass particles



Impeller utilizes pump-out vanes for balancing axial thrust

Confined casing gasket

Self-draining rear cavity port

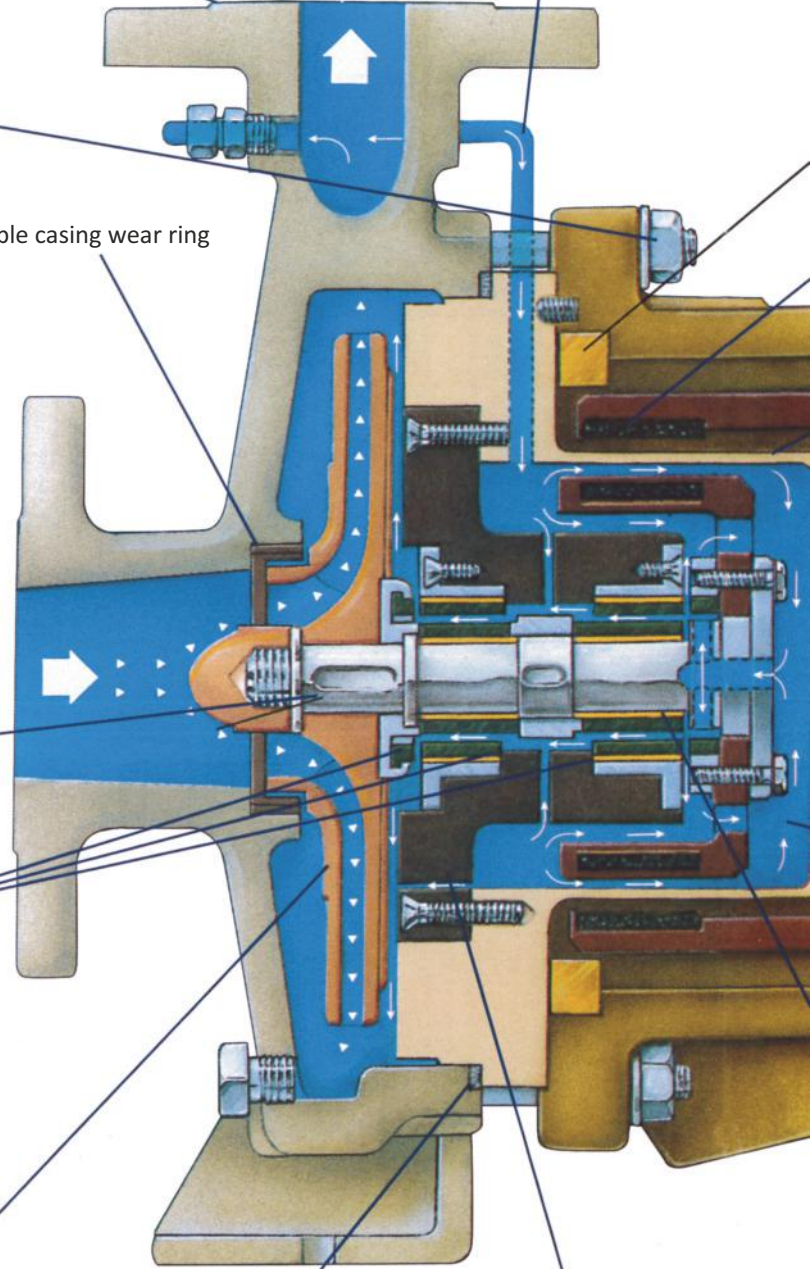

Non sparking safety ring prevents damage to containment housing

High-torque, high temperature rated samarium cobalt magnets

Standard containment housing is Hastelloy C one-piece design; no O-rings or gasket



Back-pull-out power frame-adapter housing remains in place to shield containment housing during ball bearing service

Wider ball bearing span-ball and roller type; bearings on same plane for proper oil lubrication

Oil seals; lip type or labyrinth

Rear bearing cavity operates near full discharge pressure to prevent flashing



Star tolerance ring positively locate silicon carbide bearings, absorb shaft vibrations and allow for differential thermal expansion

MAXIMUM COMPONENT INTERCHANGEABILITY

A modular design concept results in fewer spares and reduced costs. All routine maintenance components (shaft bearings and power frame) are common to all pumps within each range.

TECHNICAL DESIGN FEATURES

- Casing built with heavy wall thicknesses; flanges machined to 150# or 300# ANSI standard.
- The standard one-piece .050" Hastelloy C276 containment housing exceeds ASME pressure vessel codes; rated for 250 PSI working pressures with capabilities to 1500 PSI.
- External lubrication maintains highest pressure differential, enabling dead-head operation.
- Impeller pump-out vanes balance axial thrust.
- Silicon carbide sleeve and thrust bearings capable of intermittent dry running.
- Dual back-pull-out design; service either hydraulic end or ball bearing assembly.
- Interchangeable mag-couplings & spare parts.
- Hand-fit sleeve bearings & components.
- Replaceable casing wear ring.
- Quick-change rear cartridge assembly allows for replacement and restart-up within 10 minutes.



GPCA containment housing is isolated from forces and moments extended upon the shaft (due to hydraulic loading); internal bearing housing & shaft are supported by the pump frame.

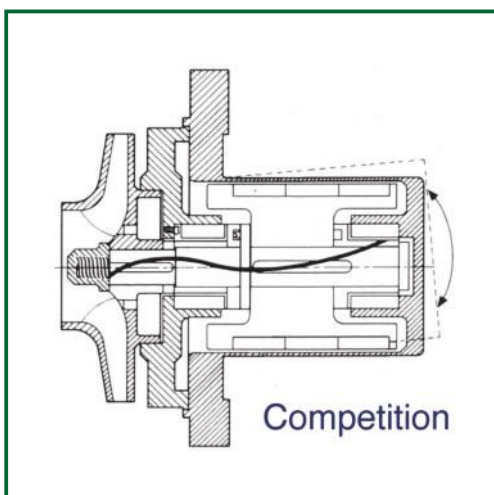
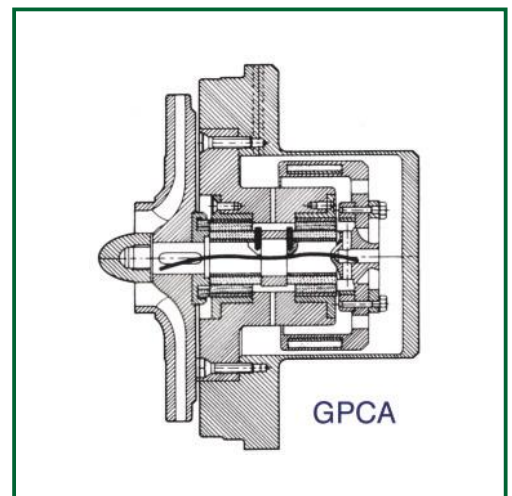

CURVE FUNZIONAMENTO DESIGN CURVES

GPCA 2900 rpm 50hz

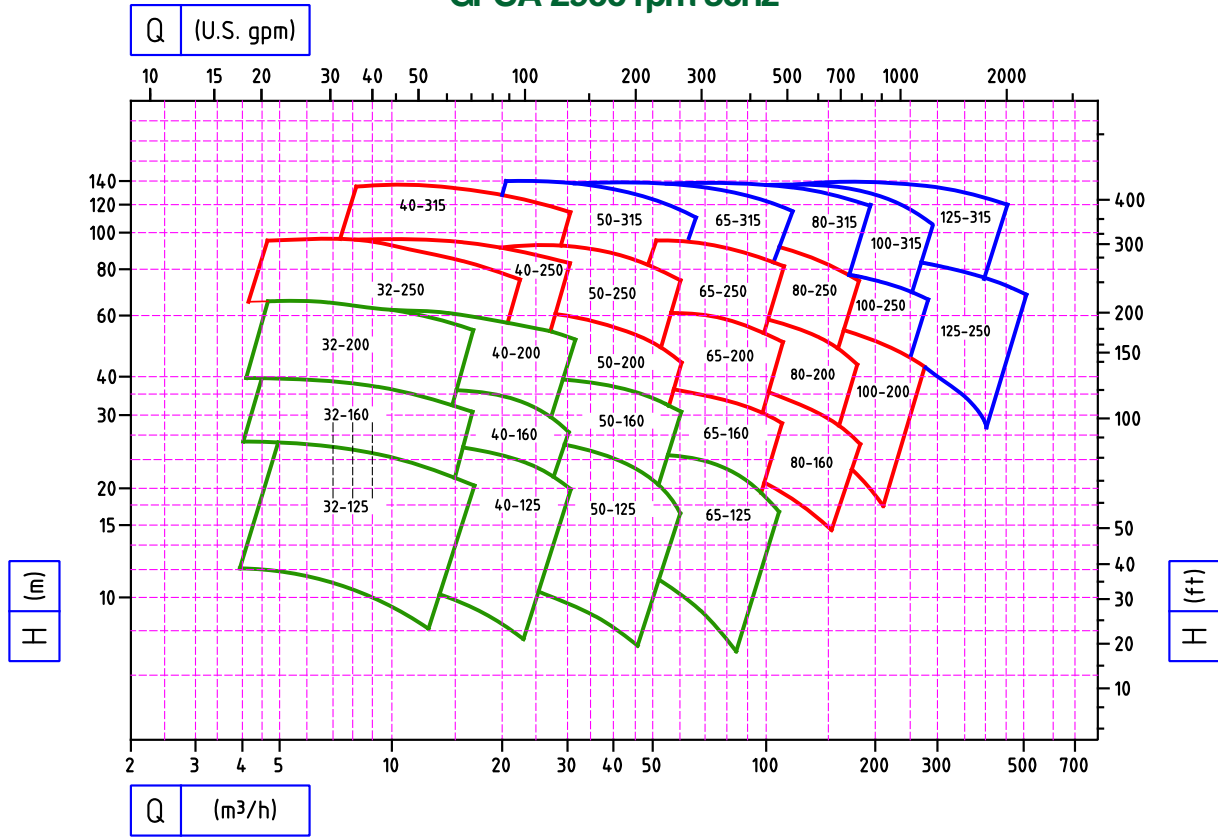

GPCA 1450 rpm 50hz

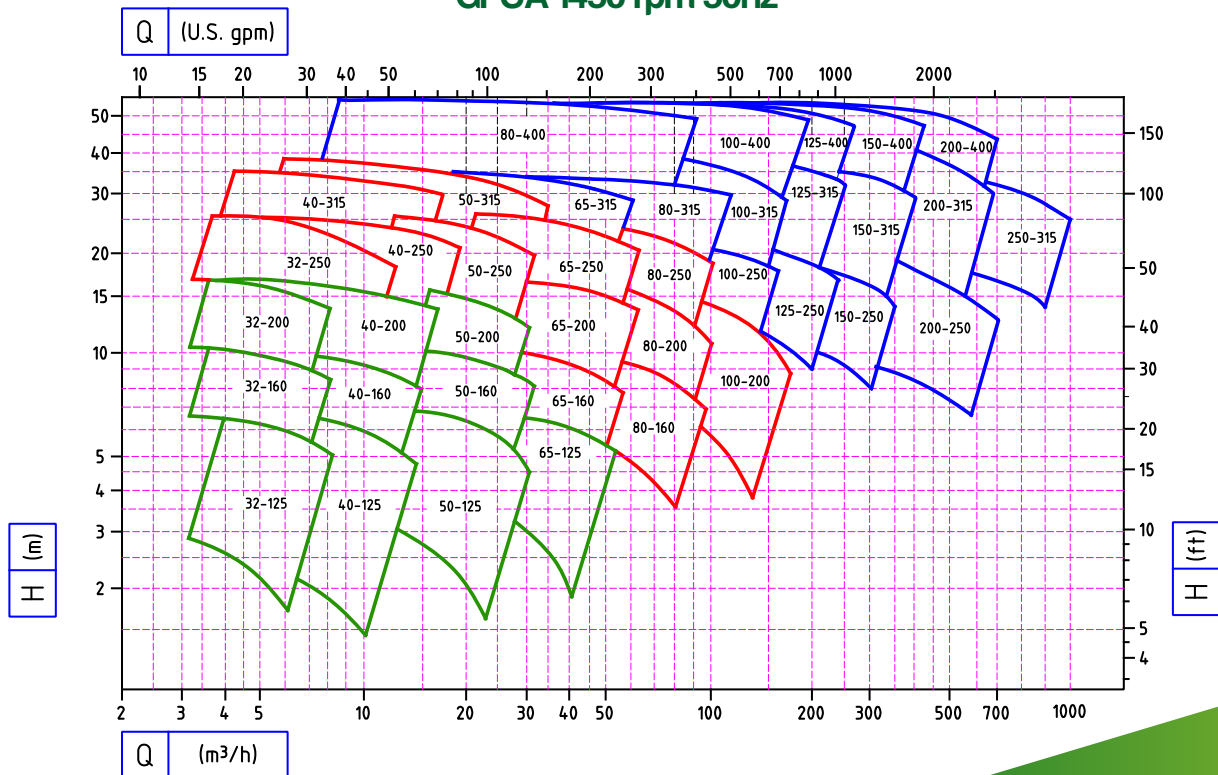

CURVE FUNZIONAMENTO DESIGN CURVES

GPCA 3500 rpm 60hz

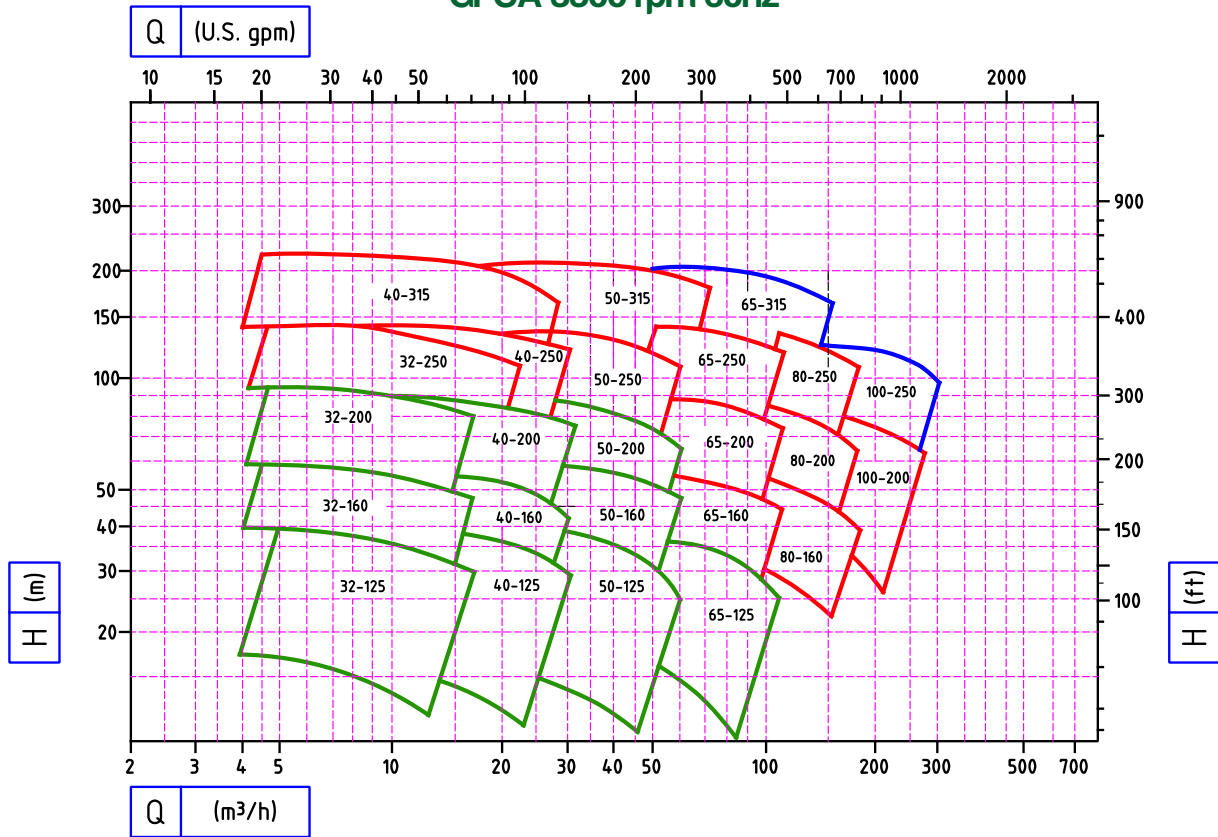

GPCA 1750 rpm 60hz

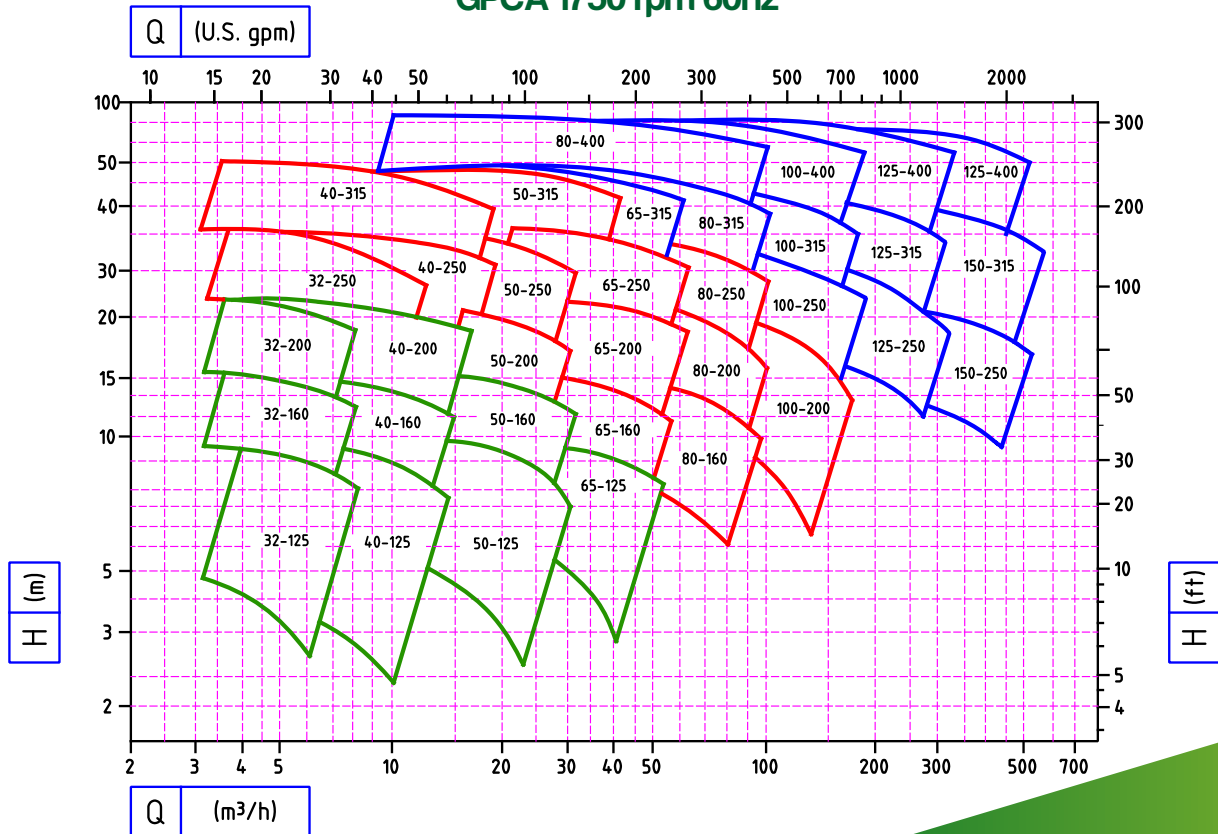

MAINTENANCE FEATURES



Quick-change cartridge.



Internal cartridge (Rear Wet End) with inducer for low NPSH.

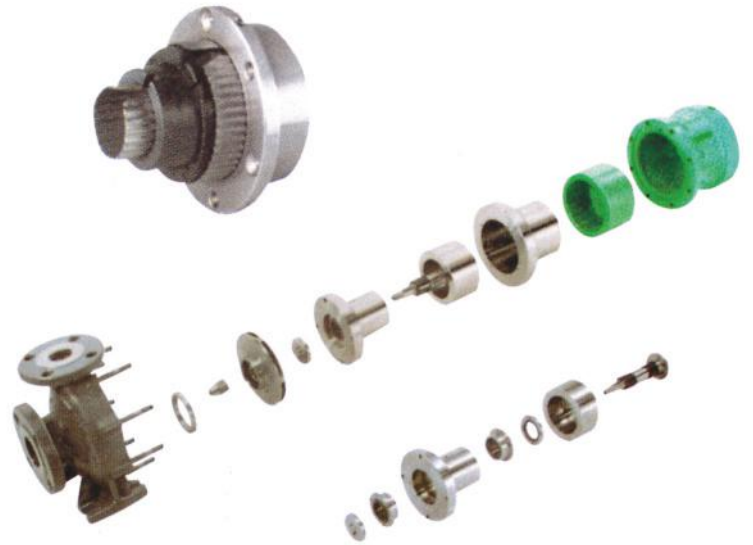

Maintenance can be performed in minutes!

GPCA pumps are designed for accessing the power frame without exposing process fluid to atmosphere; jackout screws allow for safe removal and reassembly of magnetic coupling.

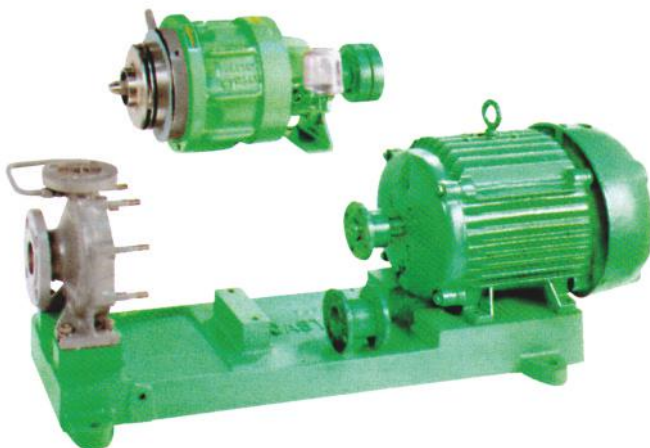
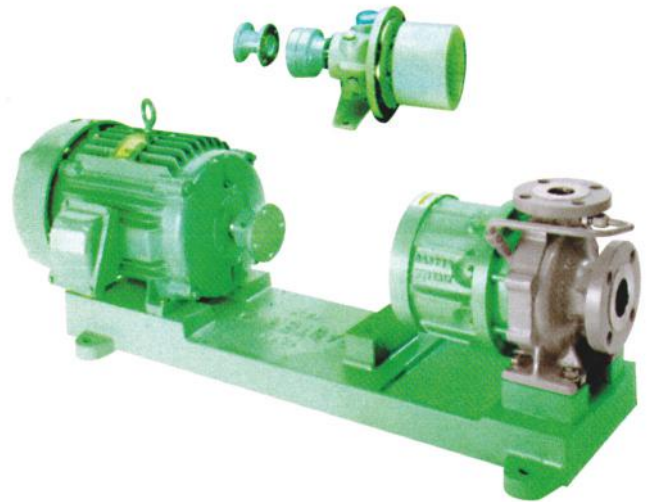

The entire impeller magnet assembly and power frame is designed for back-pull-put, leaving pipe work intact..



CASTER 

via Antonio Canova, 6/8 - 35020
Sant'Angelo di Piove di Sacco
PADOVA - IT

T +39 049 9705782

www.greenpumps.it - info@greenpumps.net

FB e IG: Greenpumps Srl

